

Alcatel Service Delivery Platform

Helping SPs Deliver Profitable Services

Chiang-Lin CHANG
VP Fixed Communication Solutions
Alcatel North East Asia SSU
chiang-lin.chang@alcatel.com.tw

Agenda

- **The Changing Landscape for Service Providers**
- Alcatel Service Delivery Platform
- Roadmaps
- Conclusion

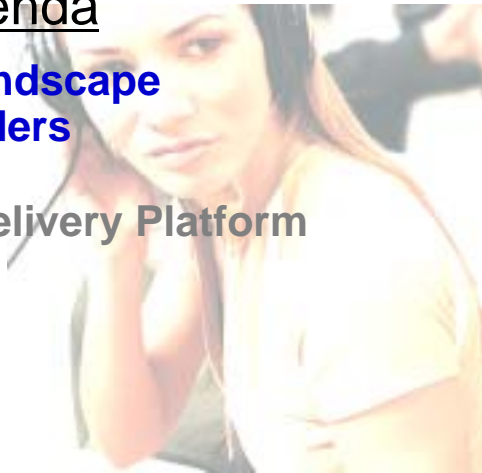

Fixed: What's Missing in Broadband Today?

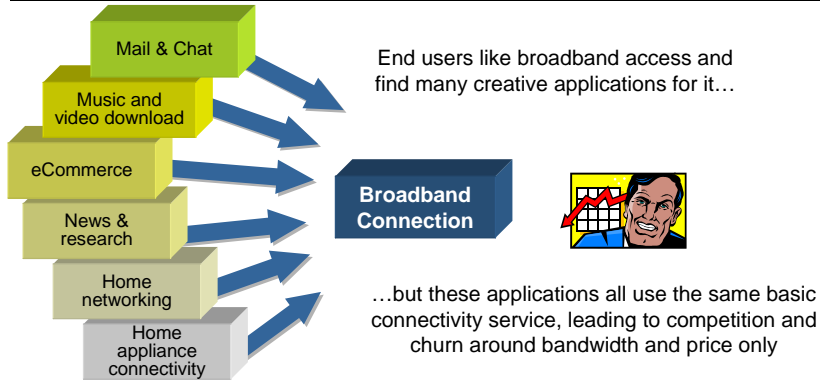

An example:
46% of ADSL users intended to change their Access Provider,
in 49% of cases the main reason was to get a lower price

Source: Survey in France by "Journal Du Net" – end 2003

Service Provider Differentiation!

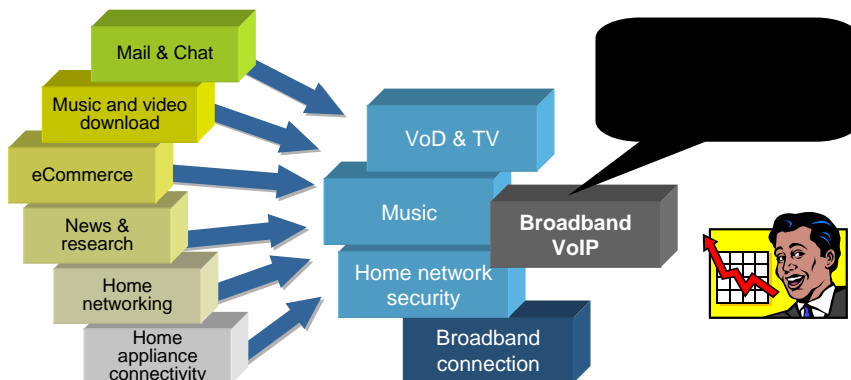

End users are prepared to pay a premium to have service bundles offered by a Service Provider, guaranteeing content renewal, legality, filtering and protection

Mobile: Data/MM Services to Drive ARPU Growth

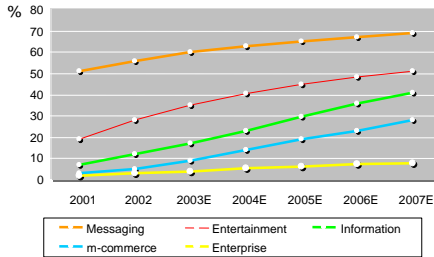
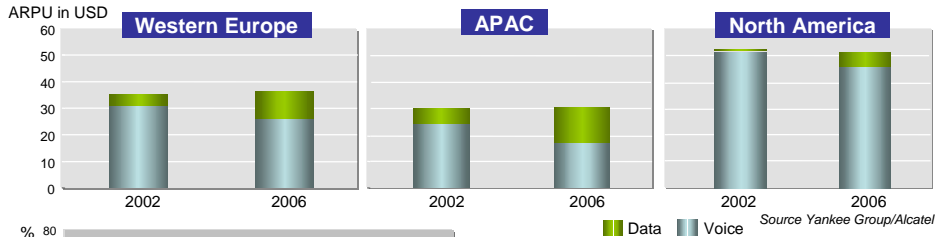

- > Data Services almost exclusively SMS in 2002
- > Evolving into a broad portfolio of multimedia services
- > Leading to the need for a SDP allowing combination and reuse

Service Providers Path to Growth

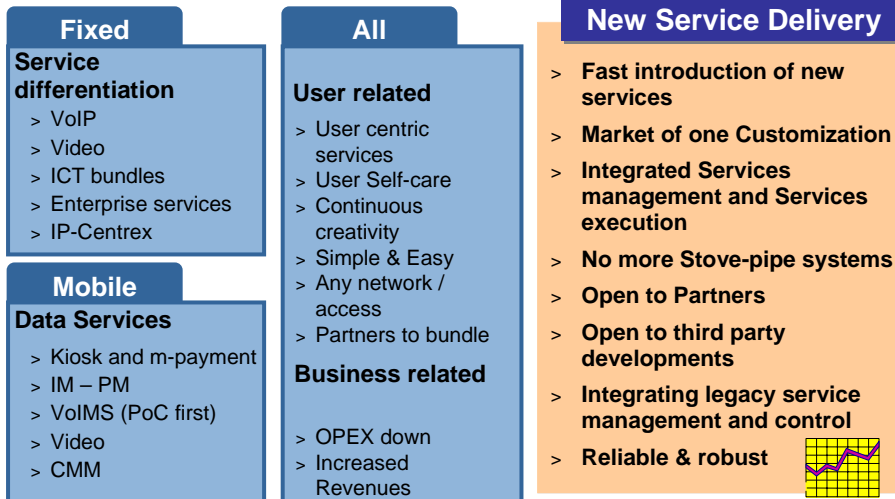

Competitive Landscape (VoIP)

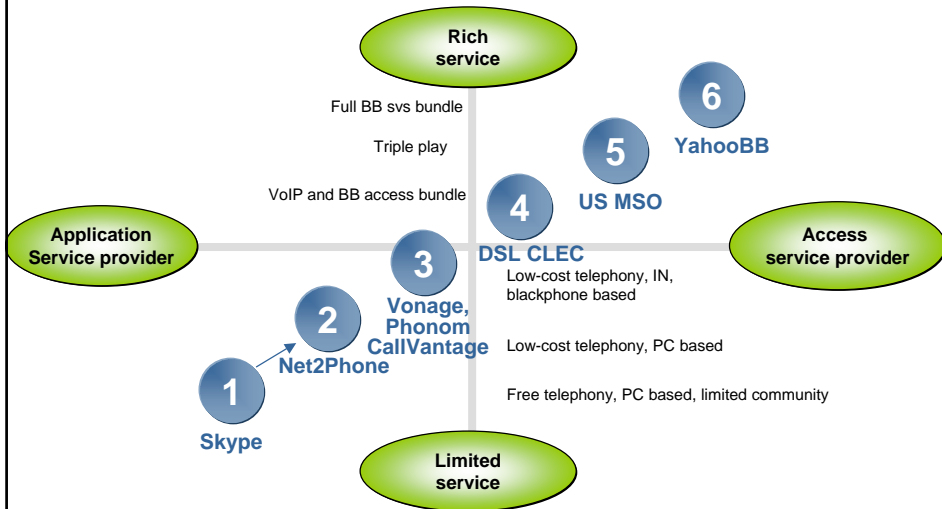

Oct. 27, 2004 BeiJing

Page 7, All rights reserved © 2004, Alcatel



Hosted VoIP Revenue Share(%) - IDC 2004

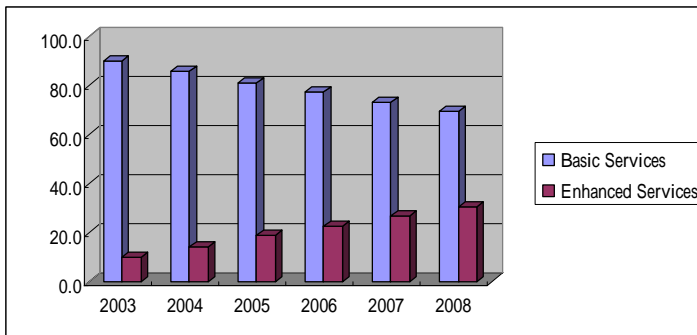

	2003	2004	2005	2006	2007	2008
Basic Services	90.0	85.5	81.2	77.2	73.3	69.6
Enhanced Services	10.0	14.5	18.8	22.8	26.7	30.4

Oct. 27, 2004 BeiJing

Page 8, All rights reserved © 2004, Alcatel



Services & Applications



Keeping the intelligence in the network
No competition between suppliers and operators

Agenda

- The Changing Landscape for Service Providers
- **Alcatel Service Delivery Platform**
- Roadmaps
- Conclusion

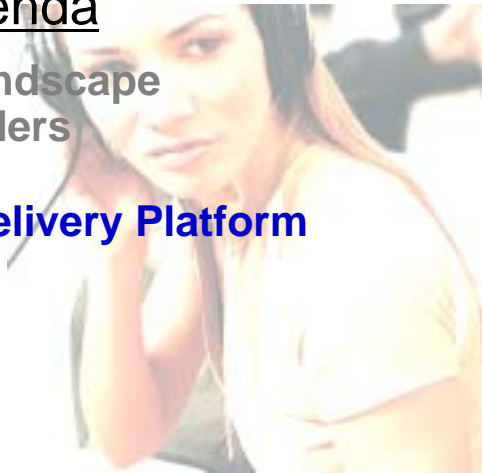

SDP Benefits: Focus on Helping SP Creativity

- **Flexibility and Reuse**
 - Flexible combination and reuse of service building blocks
 - Based on open standards (OMA Service Environment, Web Services)
 - Modular, interoperable
- **Virtualization**
 - End-user centric service definition
 - Any type of access network, compliant with IMS model
 - Service evolution and tailoring with no platform change
- **Business Agility**
 - Fast integration with business logic of the operator (Web Services)
 - Allowing easy parameterization by both operator and end-user

Alcatel's OPEN Service Delivery Platform

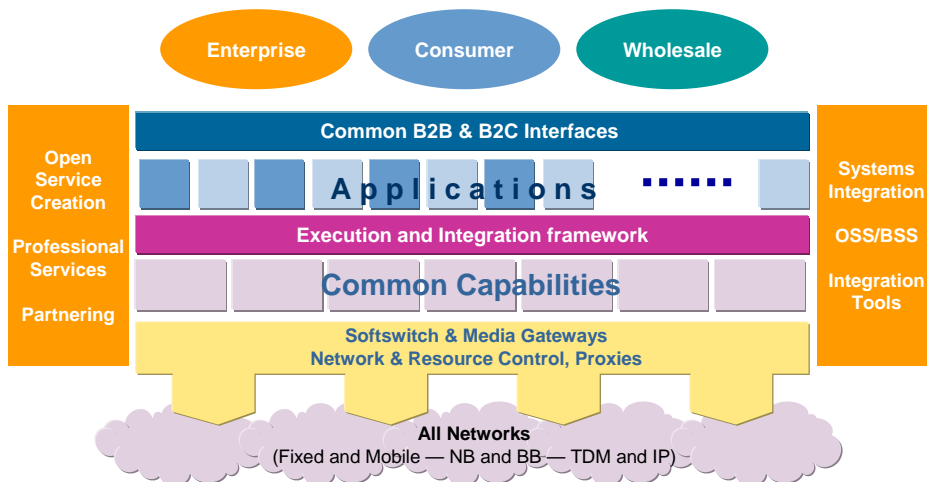

Application Architecture: An *OPEN* Service-Oriented Architecture

Third-Party Application Development and Delivery
Java, OSA/Parlay, SOAP/XML, Web Services, etc.

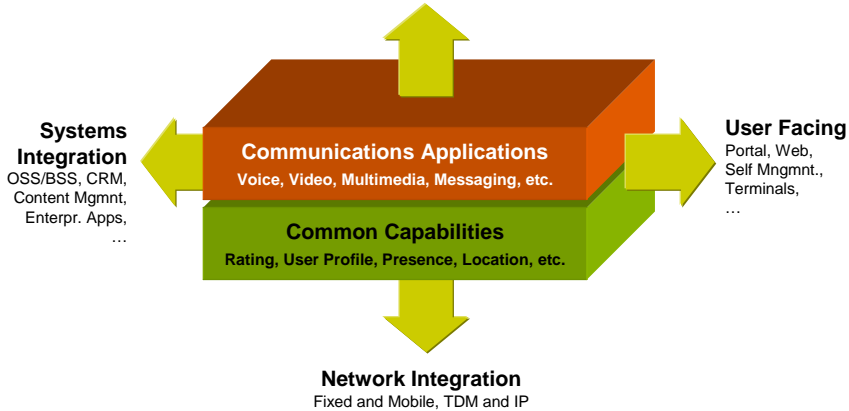

Oct. 27, 2004 BeiJing

Page 13, All rights reserved © 2004, Alcatel



Application Layer



3rd Party communications applications

3rd Party business/content applications
BEA, Websphere, .NET

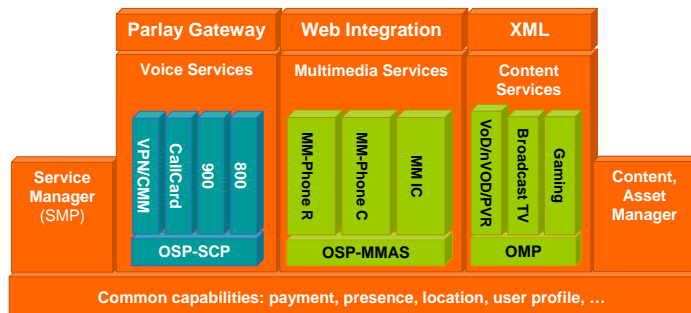

Oct. 27, 2004 BeiJing

Page 14, All rights reserved © 2004, Alcatel



Common Capabilities

- **Common capabilities are Re-Usable Functions (SOA)**

- Integrate once, use many times
- Deploy once, use for all services
- Guaranteed consistency for payment and user profile management
- Third party capabilities integrated in OPEN platform

Common Capabilities

- > Authentication
- > Real-time rating, accounting and payment
- > Presence, user based and network based
- > Location (with HLR/HSS interworking)
- > Media server for voice and multi-media
- > IVR, ASR and TTS through VxML
- > Terminal handler

Multi-Application Platform

- Both Java and C/C++ Environments, for Support of New Developments and Legacy SW
- “5 Nines” Reliability
- Telecom Response Time
- Scalability From 1 to 100+ Servers

New Platform - 2005 For SDP and Softswitch

- > IT based
- > Commercial ATCA based HW
- > Linux and telecom middleware
- > Built-in redundancy
- > Improved performance
- > Ultra-density e.g. 3.2 Million subscribers in a rack for a mobile softswitch
- > All networks interfaces



Control Layer Evolution

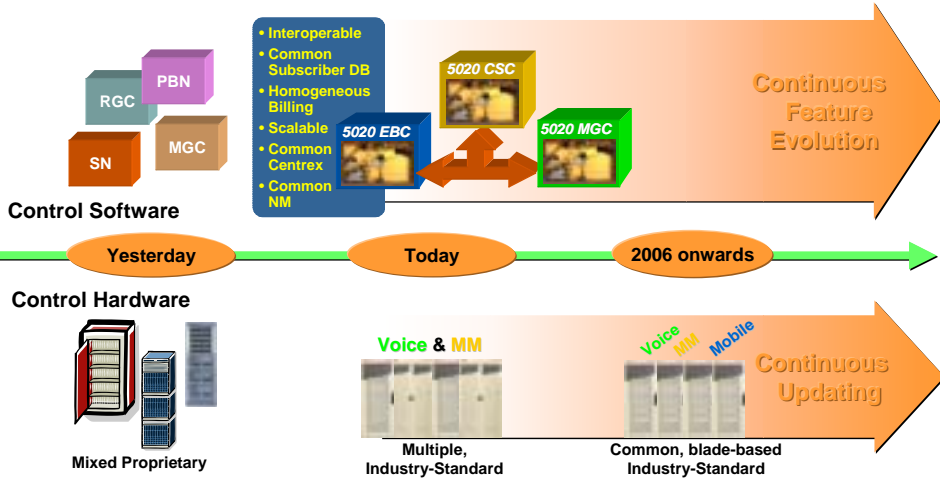

User Profile and Personalization (PSE)

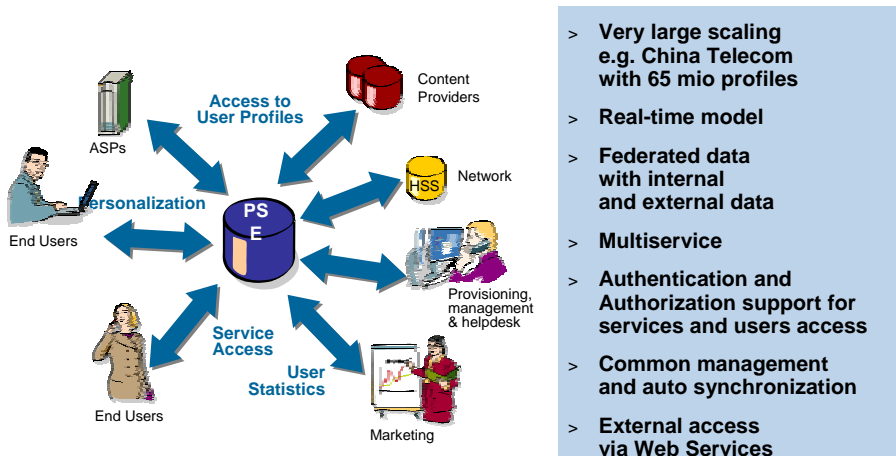

VoIP : a Real Multimedia Application

- **Web GUI** Supporting
 - hard- and soft-phones, voice, video, IM
- **Address Book** Integration
 - LDAP, Outlook, Notes
- **Click-to-call**
- **Presence** Integration
- Screen Pop-ups with **Enhanced CLI**
- Customizable **Banner**
- **Self-management**
- **Implicit Routing**
- **Flexible Payment**



**Combining VoIP and Internet into a “Best of Both Worlds”
Business Communication Service**

Agenda

- **The Changing Landscape for Service Providers**
- **Alcatel Service Delivery Platform**
- **Roadmaps**
- **Conclusion**

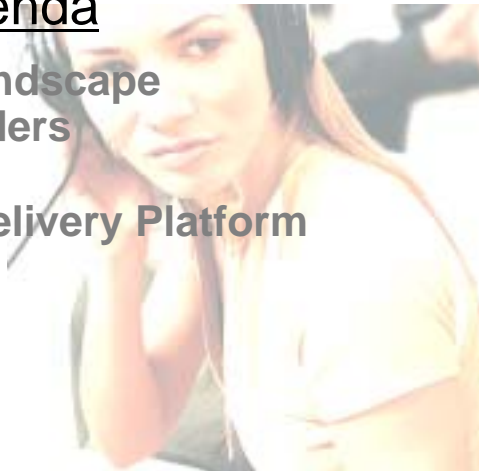

Products in the Field

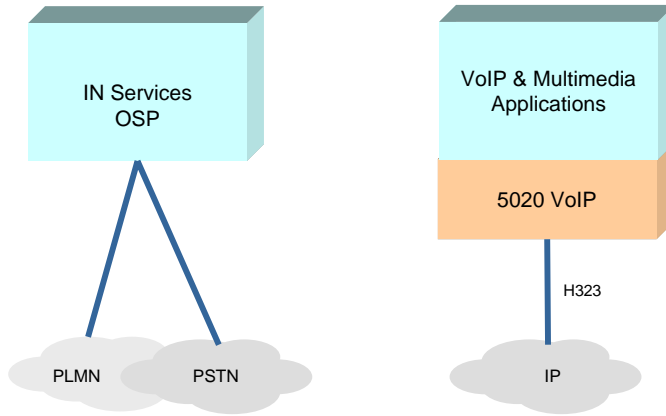

2004: OPEN NGN Architecture

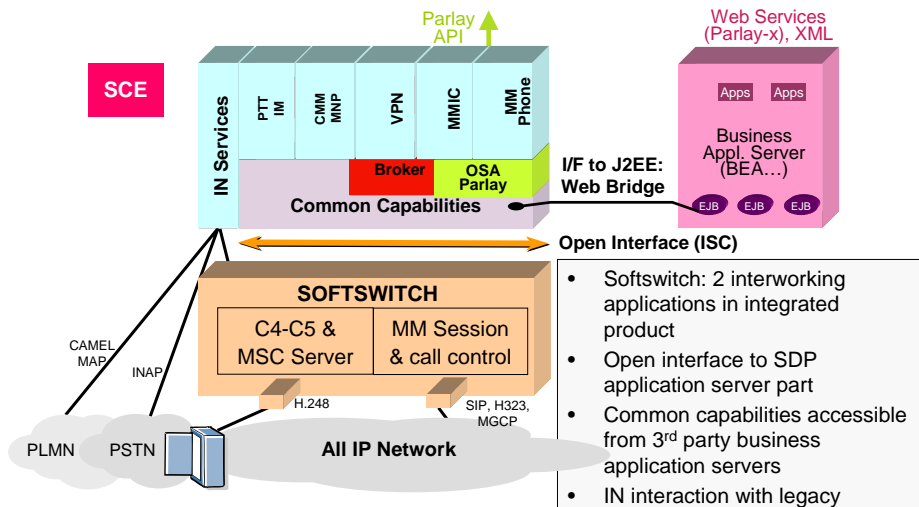

2005: Scalability & Development Efficiency

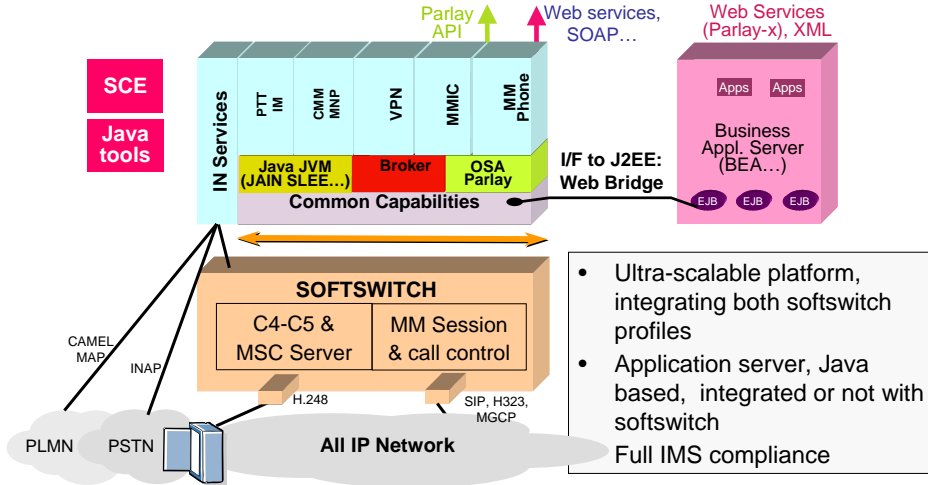

Oct. 27, 2004 BeiJing

Page 23, All rights reserved © 2004, Alcatel



2005/2006: Video for both Fixed and Mobile

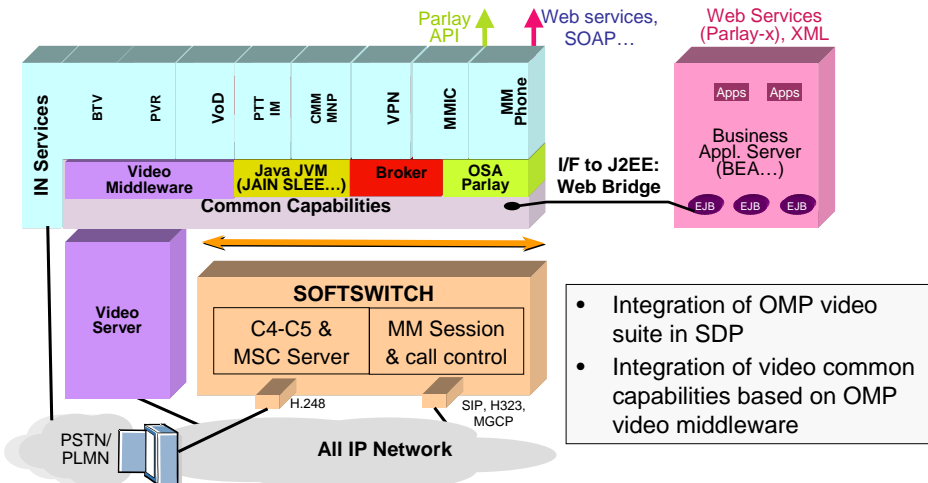

Oct. 27, 2004 BeiJing

Page 24, All rights reserved © 2004, Alcatel



ICT Platform: Application & Integration Framework

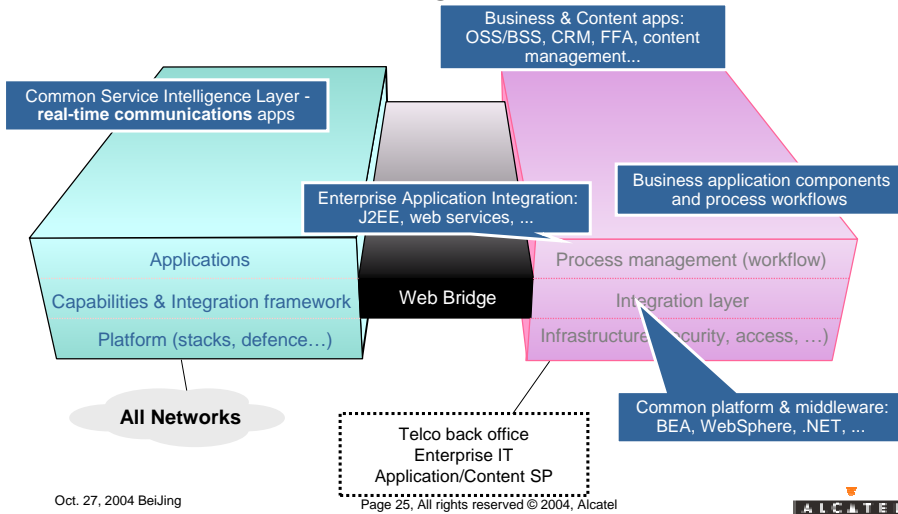

Example: Video-on-Demand

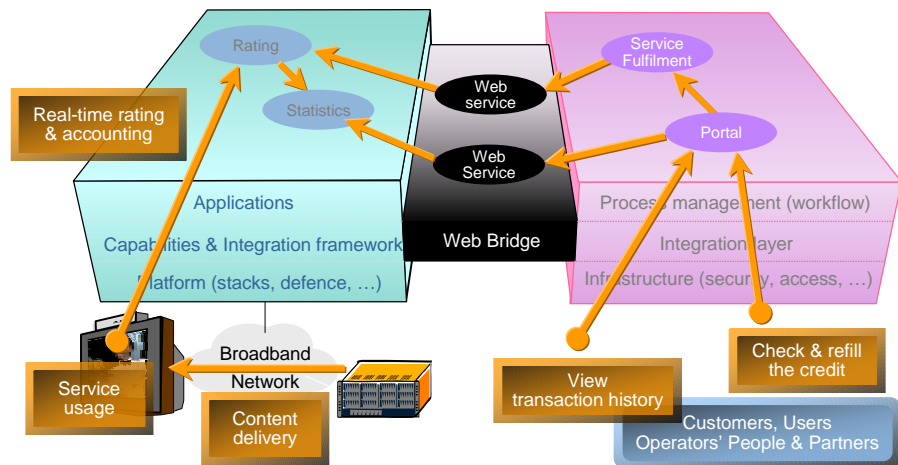

Example: Micro-payment

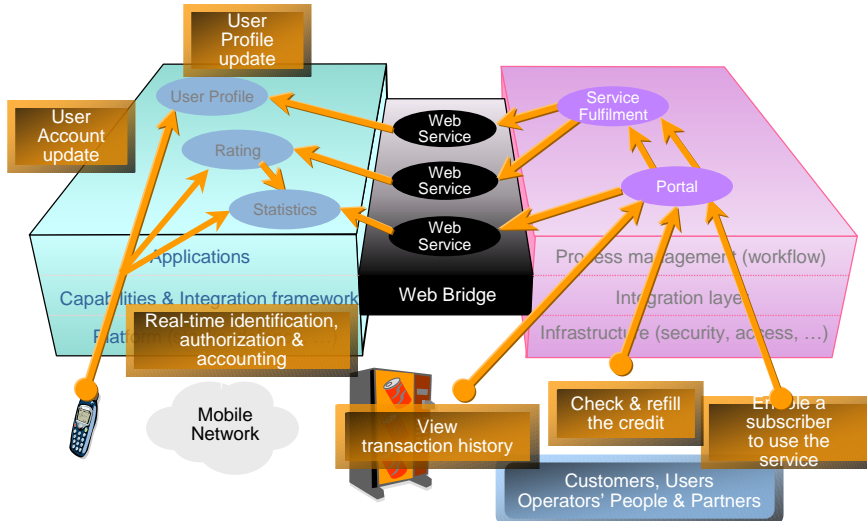

Oct. 27, 2004 BeiJing

Page 27, All rights reserved © 2004, Alcatel



Agenda

- The Changing Landscape for Service Providers
- Alcatel Service Delivery Platform
- Roadmaps
- **Conclusion**

Oct. 27, 2004 BeiJing

Page 28, All rights reserved © 2004, Alcatel



Enabling our Customers to Become Leaders in Delivering Unified User-Centric Services

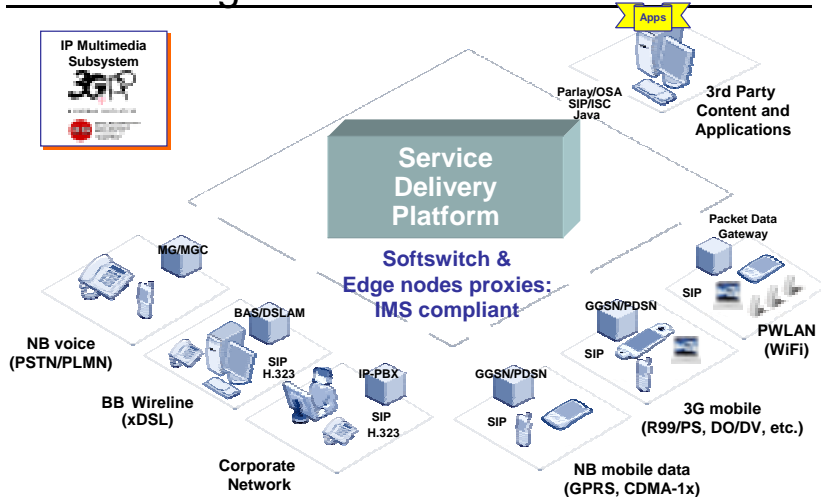

Oct. 27, 2004 Beijing

Page 29, All rights reserved © 2004, Alcatel



Our Full Service Offer

- **A full Service Delivery Platform with Optimal Reuse of Components from Alcatel and Partners**
- **A Rich Set of Re-usable Components**
- **Consumers and Enterprises Assemblies**
- **Integration Tools and Connectors for**
 - Networks: legacy, IP and Broadband
 - Terminals
 - OSS / BSS functions and processes
 - Contents
 - Business Applications and IT
 - Partners' systems
- **Integration Projects with Partners**
- **Architecture design (Advice & Assistance)**
- **Full Support and Maintenance**

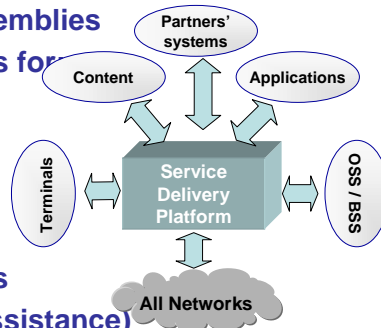

Oct. 27, 2004 Beijing

Page 30, All rights reserved © 2004, Alcatel



中国第三届 **PICMG** 技术年会 ATCA/PXI
The 3rd China Annual PICMG Tech-forum

謝 謝

www.alcatel.com



Chiang-Lin Chang (張江林)
Vice President
Fixed Communication Solutions
Alcatel North East Asia SSU
886-2-21621100 X7700
chiang-lin.chang@alcatel.com.tw

