



Intel® NetStructure™ Host Media Processing Software Release 1.0 for the Windows* Operating System

Media Processing Software That Can Be Used To Build Cost-Effective IP Media Servers

Features	Benefits
Implemented as a software-only product with a variety of media processing configurations	Minimizes investment, development, deployment, and operational costs
Support for computing platforms with Intel® Celeron®, Pentium® III, and Pentium® 4 processors with the ability to scale up to 64 media processing channels per system	Gives developers a choice of several processing platforms on which to build cost-effective IP media servers
Compliant with the ITU H.323 specification for call control	Provides easy interoperability for call control with a wide range of gateways, gatekeepers, and other IP endpoints
Support for streaming media over RTP using a G.711 voice coder with choice of packet size (10 ms, 20 ms, and 30 ms) and RFC 2833 DTMF packets	Provides the interoperability needed for high-quality media streaming with a wide variety of industry-standard IP gateways and endpoints
Support for Global Call and R4 APIs	Allows easy migration of existing applications by providing compatibility at the API level with other Intel® communications products
Administration tools that include Intel® Dialogic® configuration manager and SNMP agent software	Integrates tools that help speed time-to-market and reduce total cost of ownership
Support for voice record/play with automatic gain control and volume control in a variety of file formats including OKI ADPCM, linear A-law and μ -law PCM, and Wave	Enables developers to build high-quality voice applications such as IVR and voice mail
Detection and generation of standard DTMF and user-defined tones	Lets developers use advanced call progress analysis and media processing functionality
Conferencing features that include coaching, active talker notification, tone clamping, echo cancellation, and scalability with a maximum of 64 parties per system	Facilitates development of advanced conferencing applications
QoS threshold alarms	Improves QoS and provides specifically minimized latency and high voice quality

Intel in Communications

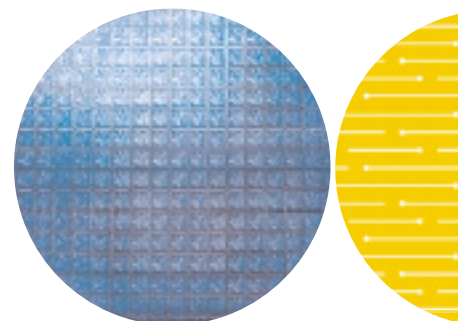

Introduction

Intel® NetStructure™ Host Media Processing (HMP) software performs media processing tasks on general-purpose servers based on Intel® architecture without using specialized hardware. The software provides media services that can be used to build flexible, scalable, and cost-effective next-generation IP media servers.

HMP software is an Intel® communications building-block technology. When installed on a system, the software looks like an Intel® Dialogic® board with DM3 architecture to the customer application, but all media processing takes place on the host processor. In order to help customers accelerate their time to market and migrate their existing applications to IP, the software also supports two direct application programming interfaces (APIs): R4 for media processing and Global Call for call control.

Release 1.0 uses a built-in network interface card (NIC) to provide IP connectivity. It supports the industry-standard H.323 protocol for call control, and RTP/RTSP for media streaming over IP in G.711 format. To help improve the quality of media streaming over the network, the software supports frame sizes of 10 ms, 20 ms, and 30 ms and additional features such as quality of service (QoS) threshold alarms.

Other important features include

- Ability to integrate any third-party call or connection control protocol stack if the H.323 protocol stack provided with the product is not satisfactory
- Support for a variety of media processing functions such as play with volume control, record with automatic gain control, DTMF, user-defined tone detection and generation (including RFC 2833), and conferencing. These functions enable customers to build advanced media processing platforms.

- Ability to scale up to 64 channels of voice and 64 channels of conferencing media processing per system, with at least 50% of CPU and memory remaining for use by an application. Also supported are advanced conferencing features such as coach/pupil mode, tone clamping, and active talker notification.

In order to guarantee real-time media processing performance, HMP software is implemented as a Windows* operating system kernel-mode driver that runs at real-time priority. The software is optimized to run on the Intel® Pentium® III and Pentium® 4 processors.

Since HMP software is implemented as a software-only product, it can be installed and upgraded as easily as any other software. The software is licensed using an industry-standard model in which the MAC address is used to node-lock the software to a particular computer.

In order to enable customers to choose the combination of media processing resources they need, HMP software is offered in a variety of licensing models. The models are listed here by the Item Market Name, which is used for ordering.

Item Market Name	RTP Sessions (G.711 only)	Voice Processing Channels	Conferencing Channels
DMIPS40AW	4	4	4
DMIPS80AW	8	8	0
DMIPS160AW	16	16	0
DMIPS320AW	32	32	0
DMIPS640AW	64	64	0
DMIPS321AW	32	32	16
DMIPS480AW	48	48	16
DMIPS322AW	32	32	32
DMIPS641AW	64	64	32
DMIPS642AW	64	64	64

Applications

- Voice mail and messaging
- IVR and announcements
- Conferencing server

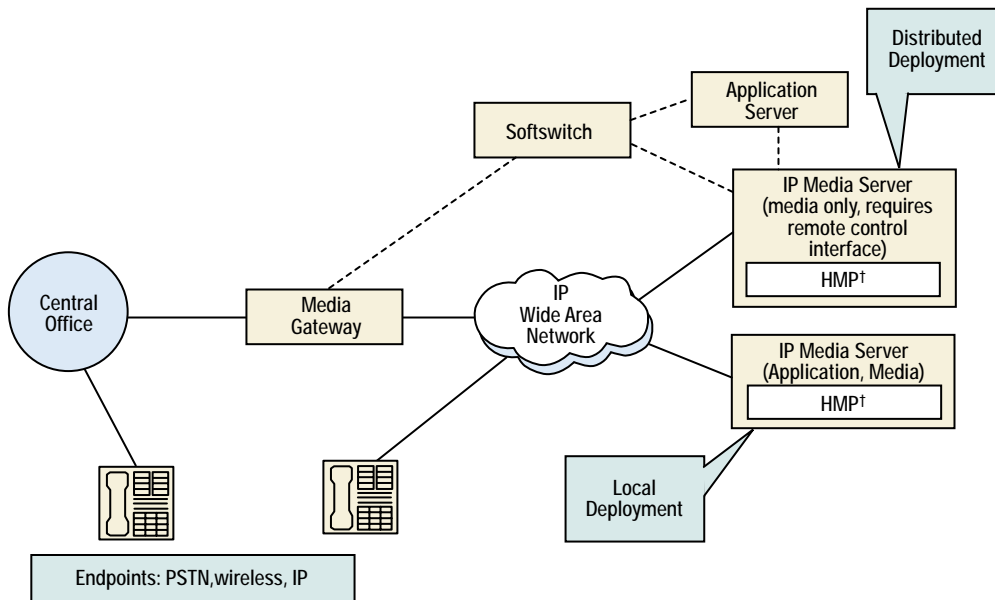

†Intel® NetStructure™ Host Media Processing software

Figure 1: HMP Software in a Service Provider Environment

Configurations

Sample configurations for IP media servers developed with HMP software include network announcements, interactive voice response (IVR), voice mail, and conferencing servers.

An IP media server is always the endpoint that terminates an IP connection in the network. Depending on the customer environment (service provider or enterprise), the IP media server can be deployed in a number of ways. The following figures illustrate typical deployment environments.

Service Provider Configuration

Figure 1 illustrates how an IP media server based on HMP software can be deployed in a typical service provider environment for IVR, announcements, voice mail, or conferencing.

An IP-PSTN gateway terminates PSTN connections. A softswitch manages all aspects of call establishment and teardown over IP. Once the call is established, an RTP connection is created between the IP media server and an endpoint. The softswitch tells the media server, IP endpoints, and IP-PSTN gateway when to establish or drop connections.

IP media servers are deployed according to two main models.

- **Local** – The application resides in the media server and controls the media processing functionality of the HMP software via direct APIs such as R4 and Global Call.
- **Remote** – The application server controls the IP media server via remote interfaces, which can be implemented using standard protocols such as SIP or HTTP and a scripting environment such as VoiceXML. In the deployment illustrated in Figure 1, the customer must implement the remote control interface on top of the direct APIs because the HMP software does not provide such an interface.

Service providers often use remote deployment because scalability and availability can be increased easily by adding more servers. Remote deployments also work better in the kind of hosted environments frequently used by service providers. However, remote deployments do have drawbacks: they are more complex and additional layers of software must be deployed to provide the remote interfaces needed to control media servers.

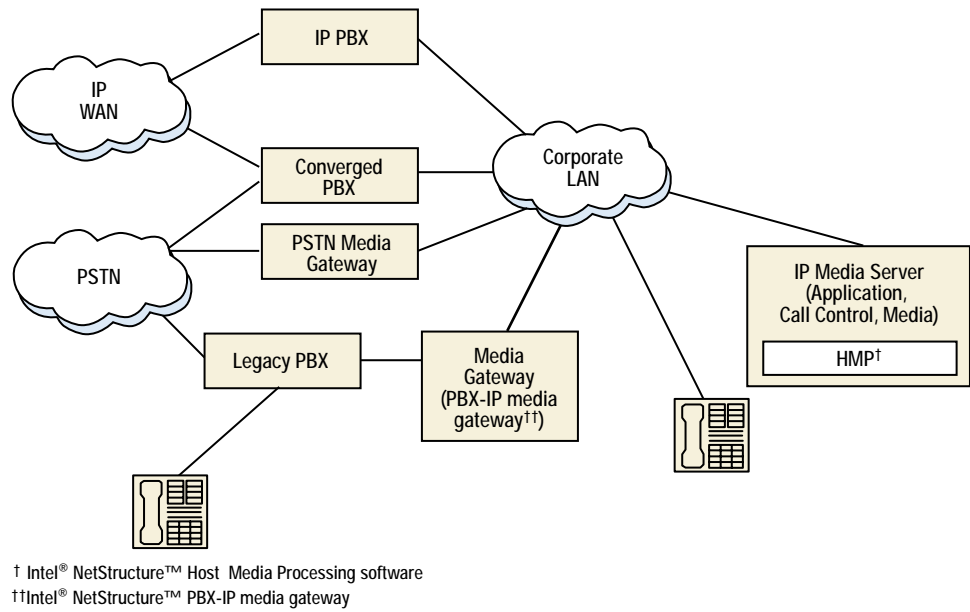

Figure 2: HMP Software in an Enterprise Environment

Enterprise Configuration

Figure 2 shows how an IP media server with HMP software can be deployed in an enterprise environment for IVR, auto attendant, voice mail, or conferencing services.

Although many legacy private branch exchanges (PBXs) are currently connected to the circuit network, new types of PBXs are evolving: converged PBXs, which are connected to both circuit and packet networks, and IP PBXs, which are connected only to the packet networks. Inside the enterprise, legacy PBXs are connected to traditional stations using analog or digital interfaces, or to the corporate intranet through gateways such as the Intel® NetStructure™ PBX-IP media gateway. Converged PBXs are connected to both traditional stations and the intranet, and IP PBXs are

connected to the intranet only. IP stations and IP media servers are connected to the intranet. The corporate intranet can also be connected to the PSTN via PSTN-IP media gateways. The increasing use of Voice over Internet Protocol (VoIP) in the enterprise has created a growing need for IP media servers.

In the enterprise environment, applications are typically deployed locally; that is, on the same computer as the IP media server because such a configuration is easier to create and maintain. However, remote deployment can also be used.

Software Support

HMP software is a standalone product. It requires no software other than the Microsoft* Windows 2000* operating system to function.

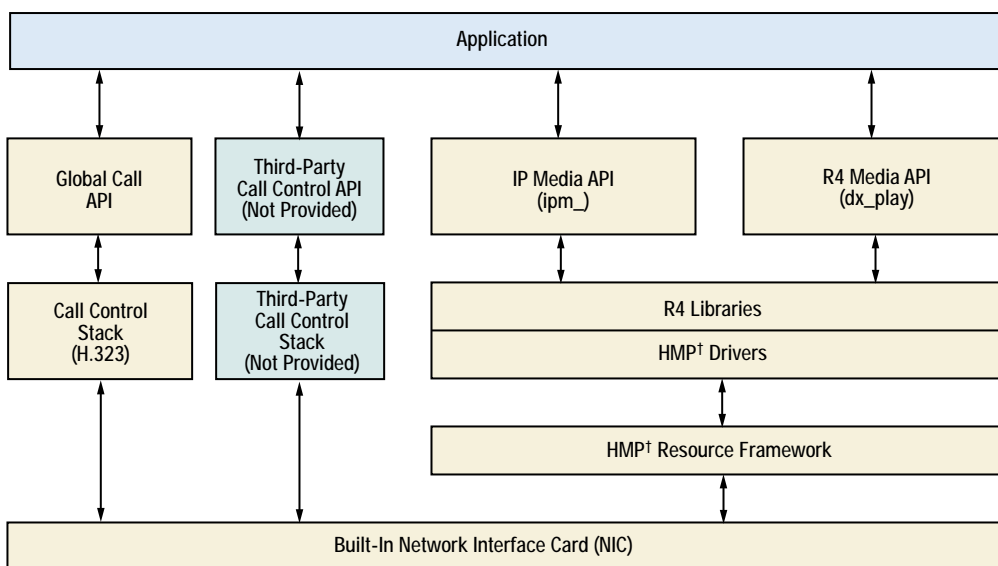

†Intel® NetStructure™ Host Media Processing software

Figure 3: HMP Software Block Diagram

Functional Description

The block diagram for HMP software is shown in Figure 3. HMP software is built in the same way that an Intel Dialogic board with DM3 architecture is built, but without any specialized hardware components.

The application deployed on top of HMP software is written to the same R4 and Global Call APIs that are used for Intel Dialogic boards with DM3 architecture. In fact, for an application there is no noticeable difference between using an Intel Dialogic board with DM3 architecture or HMP software.

For media processing, the application will use the R4 media API. For call control, there are two options.

1. The H.323 stack distributed as part of the HMP software product and the Global Call API, which simplifies development and helps in the migration of existing applications

2. A third-party call or connection control protocol stack (SIP, MGCP, Megaco) and the IP media library, which provides the functionality necessary to integrate the third-party call control stack with R4 media APIs

The APIs for HMP software are enabled through the same libraries and drivers as Intel Dialogic boards with DM3 architecture. The drivers sit on top of the HMP software resource framework, which is the core of the product. The framework implements media processing algorithms such as DTMF detection and generation, media stream mixing, etc. The algorithms, in turn, are aggregated into resources (such as player and recorder) in the same way as they are on Intel Dialogic boards with DM3 architecture.

The call control stacks and the resource framework sit on top of the standard network drivers and the network interface card (NIC) that are built into the computer.

Technical Specifications**

Network Interface

IP over a standard Ethernet connection

Call Control over IP

Call control protocol	H.323
Integration with third-party call and connection control stacks	Provided via the IP media library

Media Streaming over IP

Protocol	RTP; frame sizes 10 ms, 20 ms, and 30 ms Encoding formats: G.711 A-law, μ -law 8-bit 8 K (64 Kb/s)
QoS	Alarms, frames per packet control
Tone generation and detection	RFC 2833

API Support

Call control	Global Call over H.323 or third-party stack integrated via IP media library
Voice processing	R4 voice (dx_)
Virtual CT Bus routing	R4 routing (sc_)
Conferencing	R4 conferencing (dcb_)
IP media (QoS, etc.)	R4 IPML (ipm_)
Event reporting, device enumeration, and other related functionality	R4 SRL (sr_)

Channel Density

64 channels of voice and conferencing per system maximum

Voice Processing Features

Features supported	Play, record, and tone generation and detection
Play	Volume control and index play
Record	Automatic gain control (AGC)
Audio file formats for play/record	OKI ADPCM 24 K, 32 K G.711 A-law, μ -law 48 K, 64 K All of the above in Wave format Linear PCM 8b 11 K (Wave format only)
Tone generation and detection	Inband DTMF generation and detection User-defined global tone generation and detection (GTG, GTD) RFC 2833 tone generation and detection

Conferencing Features

Total parties per server	64
Advanced features	N-way summing Coach/pupil mode DTMF detection DTMF clamping Active talker notification

Interoperability with Other Equipment over IP

Media gateways	Intel® NetStructure™ PBX-IP media gateway Accel Elite* Cisco* 5300
IP endpoints	Polycom SoundPoint* IP 400 H.323 phone Microsoft NetMeeting* client
IP boards	Intel® NetStructure™ DM/IP IP boards Intel® NetStructure™ IPT6720C IP board (Note: Boards must be installed in a different computer.)

Technical Specifications**

Licensing

Number of configurations that can be installed on the system simultaneously	1
Enabling method	Node-locked using MAC address of the built-in Ethernet NIC

Hardware System Requirements

Memory Requirements

See table below.

System Requirements

Single-processor PCI platform with an Ethernet NIC (Note: 100BaseT is recommended.)

Processors Supported

Intel Celeron, Pentium III, and Pentium 4 processors

For minimum processing platforms and clock speeds for different media processing configurations, see table below.

Models are listed by Item Market Name. In all cases, at least 50% of the CPU can be used by the application.

Item Market Name	RTP Sessions (G.711 only)	Voice Processing Channels	Conferencing Channels	Minimal Platform with Intel® Processor Channels	Memory Required
DMIPS40AW	4	4	4	Celeron, 566 MHz	256 MB
DMIPS80AW	8	8	0	Celeron, 566 MHz	256 MB
DMIPS160AW	16	16	0	Pentium III, 850 MHz	512 MB
DMIPS320AW	32	32	0	Pentium III, 850 MHz	512 MB
DMIPS640AW	64	64	0	Pentium III, 1.2 GHz	512 MB
DMIPS321AW	32	32	16	Pentium III, 1.2 GHz	512 MB
DMIPS480AW	48	48	16	Pentium III, 1.2 GHz	512 MB
DMIPS322AW	32	32	32	Pentium III, 1.2 GHz	512 MB
DMIPS641AW	64	64	32	Pentium 4, 2.0 GHz	512 MB
DMIPS642AW	64	64	64	Pentium 4, 2.0 GHz	512 MB

Operating System Requirements

Microsoft Windows 2000 Service Pack 2

To learn more, visit our site on the World Wide Web at <http://www.intel.com>.

1515 Route Ten
Parsippany, NJ 07054
Phone: 1-973-993-3000

INFORMATION IN THIS DOCUMENT IS PROVIDED IN CONNECTION WITH INTEL® PRODUCTS. NO LICENSE, EXPRESS OR IMPLIED, BY ESTOPPEL OR OTHERWISE, TO ANY INTELLECTUAL PROPERTY RIGHTS IS GRANTED BY THIS DOCUMENT. EXCEPT AS PROVIDED IN INTEL'S TERMS AND CONDITIONS OF SALE FOR SUCH PRODUCTS, INTEL ASSUMES NO LIABILITY WHATSOEVER, AND INTEL DISCLAIMS ANY EXPRESS OR IMPLIED WARRANTY, RELATING TO SALE AND/OR USE OF INTEL PRODUCTS INCLUDING LIABILITY OR WARRANTIES RELATING TO FITNESS FOR A PARTICULAR PURPOSE, MERCHANTABILITY, OR INFRINGEMENT OF ANY PATENT, COPYRIGHT OR OTHER INTELLECTUAL PROPERTY RIGHT. Intel products are not intended for use in medical, life saving, life sustaining applications.

Intel may make changes to specifications and product descriptions at any time, without notice.

Intel, Celeron, Intel Dialogic, Intel NetStructure, Pentium, and the Intel logo are trademarks or registered trademarks of Intel Corporation or its subsidiaries in the United States and other countries.

*Other names and brands may be claimed as the property of others.

